



Pro Plus Architectural Specification

For LED Neon Flex Ribbon

Side/Top View

Table of Contents

Introduction	03
1. Specifications & Parameters	04
1.1 Dimensions of Light	
1.2 Technical Parameters	
1.3 Optical Parameters	
2. Functions & Features	05
2.1 Product Features	
2.2 Minimum Bend Diameter	
3. Types of Connector	05
3.1 Injection-moulded Connector	
3.2 Snap Connector	
3.3 Swivel Connector	
3.4 Anti-wicking Ferrule	
3.5 Male & Female Connector	
4. Mounting Profile	09
4.1 Plastic Profile	
4.2 Spring Clip Aluminum Profile	
4.3 Hybrid Profile	
4.4 Cable Exit Oriented Aluminum Profile	
(Applicable to Injection-moulded Connector Only)	
4.5 Corner Aluminum Profile	
(Applicable to Injection-moulded Connector Only)	
4.6 Bendable Stainless Steel Profile	
4.7 Recessed Mounting Profile	
5. Packaging	14
6. Appendix	14
6.2 Certificate	
6.3 Third-Party Test Report	
6.4 Reliability Test of Light	
6.5 Figures of Typical Characteristics	
6.6 (X,Y) Chromaticity Diagram	
6.7 Correlated Color Temperature	
6.8 Loading Chart	
6.9 Wavelength of Color Light	

Introduction

Pro Plus Architectural is UL/cUL, CE and RoHS compliant. Moreover, it has been passed environmental resistance, optical, mechanical and electrical tests in our lab under the support of advanced experimental equipment and technology to ensure it meets the requirements of harsh environments. Also, it has been passed relevant tests of third party inspection authority.

Fully encapsulated in the silicone chamber by utilizing consummate extrusion technology, assembled with injection-moulded connectors to achieve IP67 protection, easy for installation and applicable for various circumstances.

Pro Plus Architectural is available in wide range of white color temperatures with only one bin and high CRI LEDs, Red, Blue, Green and Amber colors are also optional, which enables endless possibilities of application.

Due to its refined internal structure, the maximum continuous length is 50% longer than its PVC version.

Applications:

1. Outdoor or Indoor Contour/Border Lighting
2. Architectural Outline/Decorative Lighting
3. Cove/Accent Lighting
4. Facade/Terrace Floor Lighting
5. Display Lighting

1. Specifications & Parameters

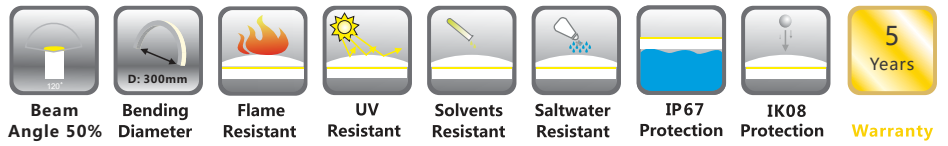

1.1 Dimensions of Light

Vertical Bend

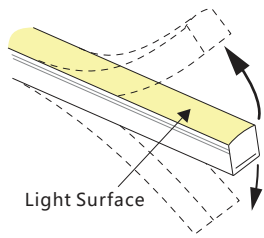

Horizontal Bend

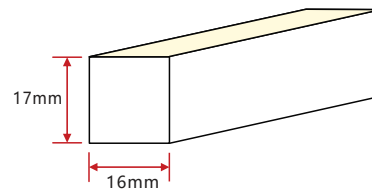
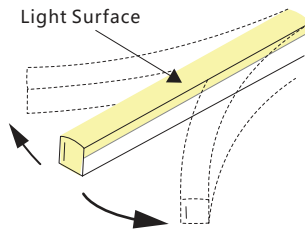

Note: Unless otherwise stated, the tolerance of the light is $\pm 0.3\text{mm}$.

1.2 Technical Parameters

Technical Parameters

Article No.	Pro Plus Architectural	Pro Plus Architectural
Color	Red/Amber	White/Green/Blue
Working Voltage	DC24V	DC24V
Rated Power/m	8W	12W
LED Qty/m	108LEDs	108LEDs
LED Distance	9.26mm	9.26mm
Min. Cutting Unit	9LEDs (1unit)	6LEDs (1unit)
Min. Cutting Length	83.3mm(1unit)	55.6mm(1unit)
Continuous Length	20m	15m
Package Length	$\leq 36\text{m}$	
Weight/m	365g	
Storage Temperature	$-40\sim 60^{\circ}\text{C}$	
Ambient Working Temperature	$-40\sim 55^{\circ}\text{C}$	
Ambient Installation Temperature IP	$-40\sim 45^{\circ}\text{C}$	
Rating	IP67	

1.3 Optical Parameters

Photometric Data

Article No.	Pro Plus Architectural					
LED Type	SMD					
Beam Angle 50%	120°	VB	HB		VB	HB
Color	Wavelength	Lumen/m	Lumen/m	CCT	Lumen/m	Lumen/m
Red	618-624nm	>185lm	>165lm	2200K	>450lm	>400lm
Green	522-528nm	>550lm	>450lm	2700K	>550lm	>450lm
Blue	468-474nm	>120lm	>110lm	3000K	>550lm	>500lm
Amber	588-594nm	>185lm	>165lm	4000K	>550lm	>500lm
				5700K	>550lm	>500lm

Candle power distribution Illuminance Characteristics

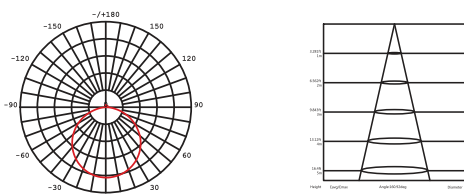

2. Functions & Features

2.1 Product Features

1. High quality SMD LED chip.
2. Protection Circuit: Each LED Protected.
3. UV & flame resistant construction(silicone).
4. Extremely flat profile for slimline projects.
5. Perfect uniform & even light source with invisible light dots.
6. High illumination.
7. Easily to be installed.
8. High IP rating (IP67)
9. The product IP rate is ultimately in line with properly applied IP rated connectors.
10. Continuous length up to 15 by powering one end.
11. Environmentally friendly & energy efficient.
12. Automated production, high reliability & long warranty.
13. 5 years life span.

2.2 Minimum Bend Diameter

Vertical Bend

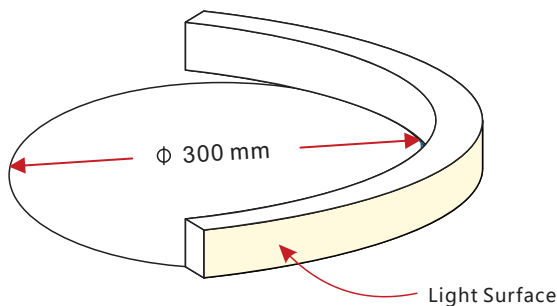

Horizontal Bend

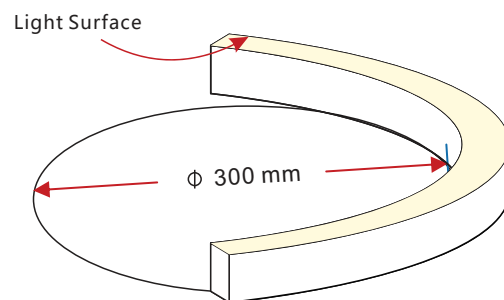

The light can only be bent along the light surface. Do not bend smaller than allowed minimum bend diameter.

3. Types of Connector

3.1 Injection-moulded Connector

Note:

1. Unless otherwise stated, the tolerance of the connector is $\pm 0.5\text{mm}$;
2. Continuous length up to 15m (G/B/W) /20m(R/A) by powering one end.



Injection-moulded Front Connector (bottom)

Connects light to power supply with pre-installed bottom feed cable IP67. Available in 0.3m, 1m, 3m, 5m, 10m lengths.

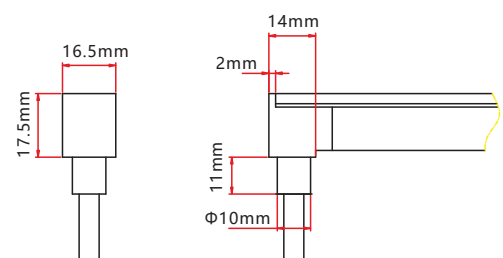



Injection-moulded Front Connector (side)

Connects light to power supply with pre-installed side feed cable, IP67. Available in 0.3m, 1m, 3m, 5m, 10m lengths.

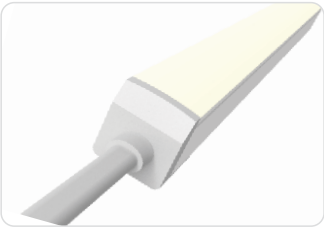
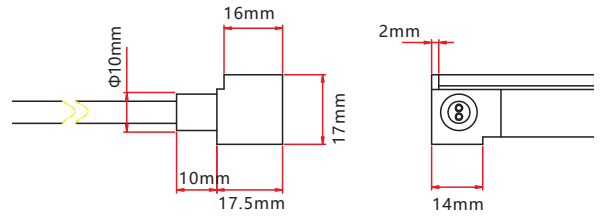

Injection-moulded Front Connector (end)

Connects light to power supply with pre-installed end feed cable, IP67. Available in 0.3m, 1m, 3m, 5m, 10m lengths.

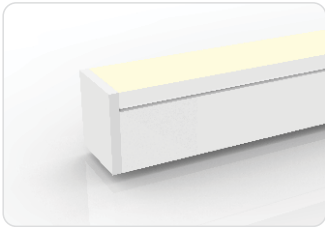
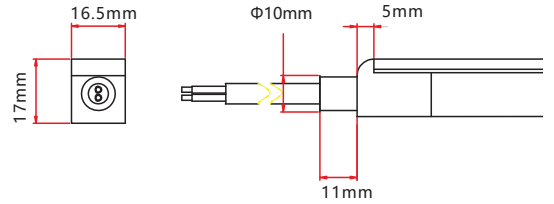

Injection-moulded End Cap

Pre-installed termination protection of the light, IP67.

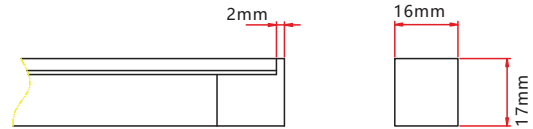

Injection-moulded Jumper

Connects two pieces of lights together with a flexible cable. IP67 Injection-moulded connector. L available in 0.3~1m.

Maximum 8 Jumpers in 20m
Maximum 4 Jumpers in 10m

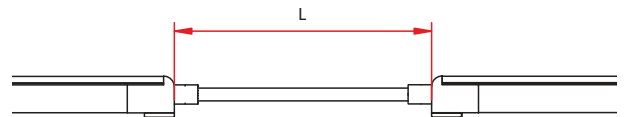

Injection-moulded T-feed

Connects two pieces of lights together with a T joint, energized from middle. IP67 Injection-moulded connector. L1 and L2 available in 0.15~0.5m. L3 available in 0.3-3m.

Maximum 8 T-feeds in 20m
Maximum 4 T-feeds in 10m

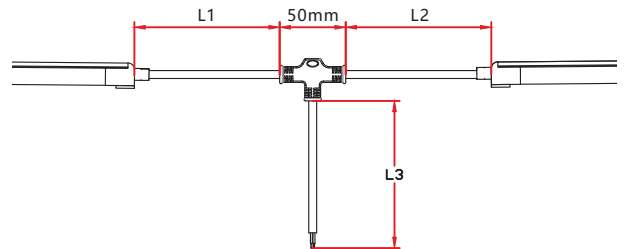

3.2 Snap Connector

Note:
 1. Unless otherwise stated, the tolerance of the connector is $\pm 0.5\text{mm}$;
 2. Continuous length up to 15m (G/B/W) /20m(R/A) by powering one end.

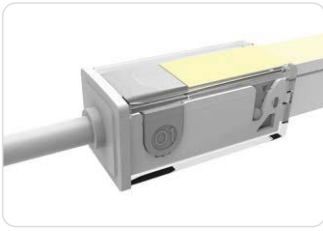

Snap Front Connector(top end)

Connects light to power supply, IP67 DIY connector. Cable available in 0.3m, 1m, 3m, 5m, 10m, 15m, 20m lengths.

Feed connector with silicone gasket *1
 (Two-pin)
 Anti-skidding clip *1
 U steel plate *1
 PC Cover *1

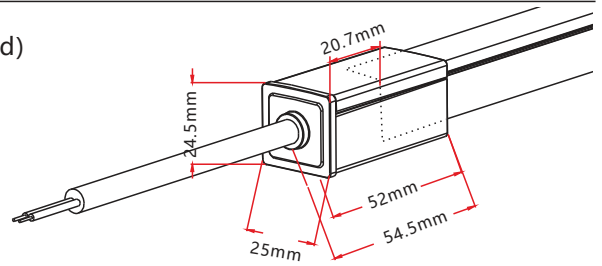

Snap Front Connector(side right/left)

Connects light to power supply, IP67 DIY connector. Cable available in 0.3m, 1m, 3m, 5m, 10m, 15m, 20m lengths.

Feed connector with silicone gasket *1
 (Two-pin)
 Anti-skidding clip *1
 U steel plate *1
 PC Cover *1

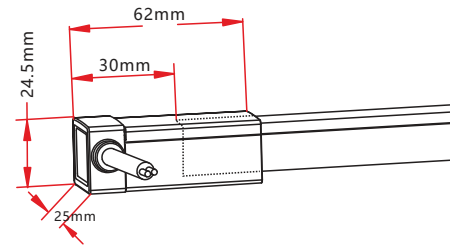

Snap Front Connector(bottom)

Connects light to power supply, IP67 DIY connector. Cable available in 0.3m, 1m, 3m, 5m, 10m, 15m, 20m lengths.

Feed connector with silicone gasket *1
 (Two-pin)
 Anti-skidding clip *1
 U steel plate *1
 PC Cover *1

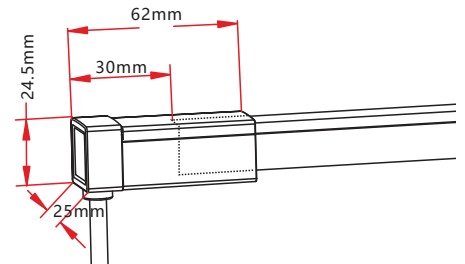

Snap End Cap

Termination protection of the light, IP67 DIY connector.

Tail plug with silicone gasket *1
 Anti-skidding clip *1
 U steel plate *1
 PC Cover *1

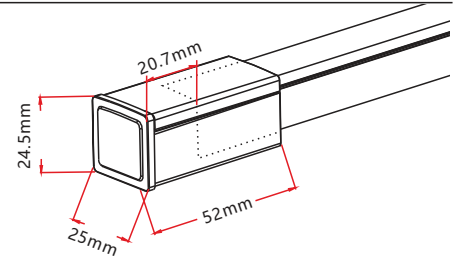

Snap Jumper

Connects two pieces of lights together with a flexible cable. IP67 DIY connector. L available in 0.3m, 1m and 3m.

Double-end feed connector*1 (Two-pin)
 Silicone gasket*2
 U steel plate*2
 Anti-skidding clip*2
 PC cover*2

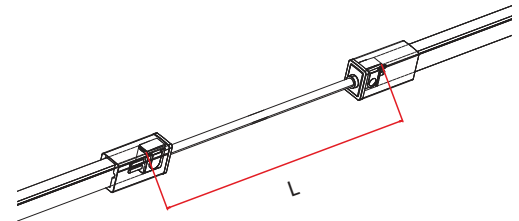

Snap Power T-feed

Connects two pieces of lights together with a T joint, energized from middle. IP67 DIY connector. L1 and L2 available in 0.3m.

T joint*1 (Two-pin)
 Silicone gasket*2
 U steel plate*2
 Anti-skidding clip*2
 PC cover*2

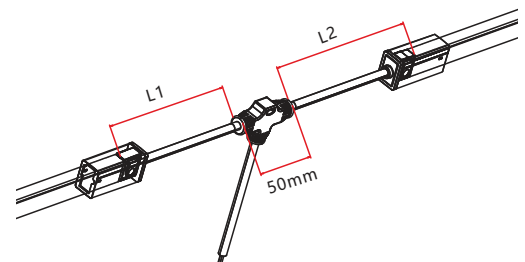

3.3 Swivel Connector

Note:

1. Unless otherwise stated, the tolerance of the connector is $\pm 0.5\text{mm}$;
2. Continuous length up to 5m (G/B/W) / 8m(R/A) by powering one end.

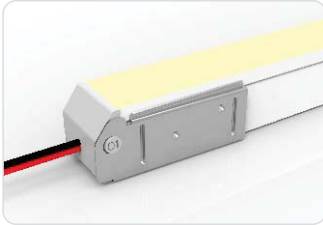

Swivel Front Connector (top end)

Connects light to power supply. IP20 DIY connector. Cable length available in 0.3m, 1m.

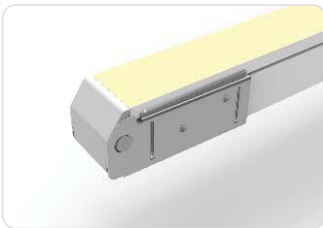
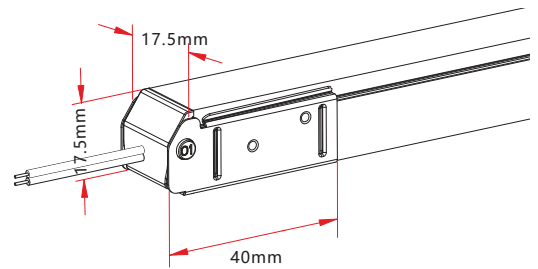

Swivel End Cap

Termination protection of the light, IP20 DIY connector.

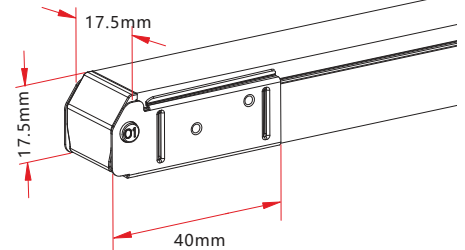

3.4 Anti-wicking Ferrule

Note: Unless otherwise stated, the tolerance is $\pm 0.5\text{mm}$.

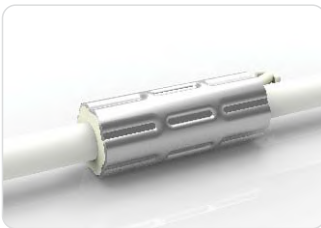

Anti-wicking Ferrule

The anti-wicking ferrule is located at 115mm ($\pm 5\text{mm}$ tolerance) from the connector on the cable.

For protection against water ingress from inside of cable wire and hence damage the light.

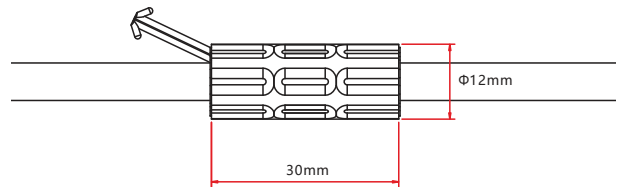

3.5 Male & Female Connector

Note: Unless otherwise stated, the tolerance is $\pm 2\text{mm}$.



Male & female Connector

For plug and play cable junction, DIY or Pre-installed connector, IP68

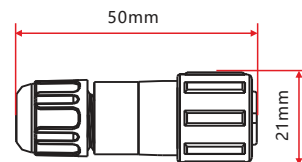

4. Mounting Profile

4.1 Plastic Profile

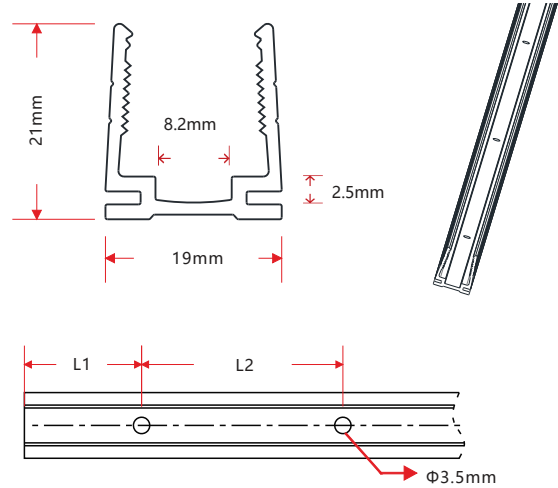
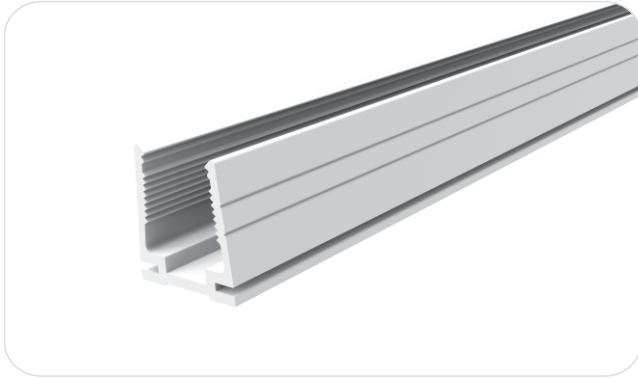

Note: Unless otherwise stated, the tolerance of the profile is ±0.5mm.

Installation Way



Model	W*H(mm)	Standard Length (mm)	L1 (mm)	L2 (mm)	Screw Hole (mm)	Hole Number	For Product
F22-PC/PL	19*21	500	50	200	Φ3.5	3	F22
		1000	100	200	Φ3.5	5	F22
		2000	100	200	Φ3.5	10	F22

4.2 Spring Clip Aluminum Profile

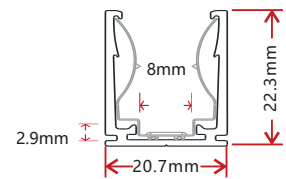
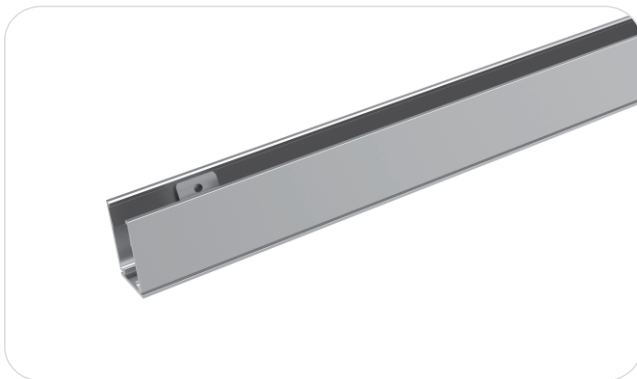

Note: Unless otherwise stated, the tolerance of the profile is ±0.5mm.

Installation Way

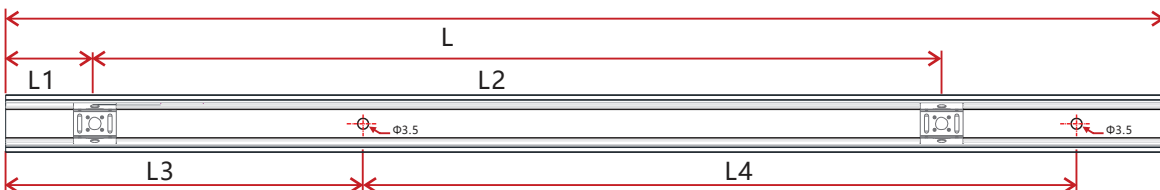

Model	W*H(mm)	Standard Length(mm)	L1(mm)	L2(mm)	L3(mm)	L4(mm)	Hole Screw(mm)	Hole Number	Clip Number
F22-SCA/PL	20.7*22.3	35	17.5	/	5	25	Φ3.5	2	1
		500	25	150	50	200	Φ3.5	3	4
		1000	25	190	100	200	Φ3.5	5	6
		2000	25	195	100	200	Φ3.5	10	11

4.3 Hybrid Profile

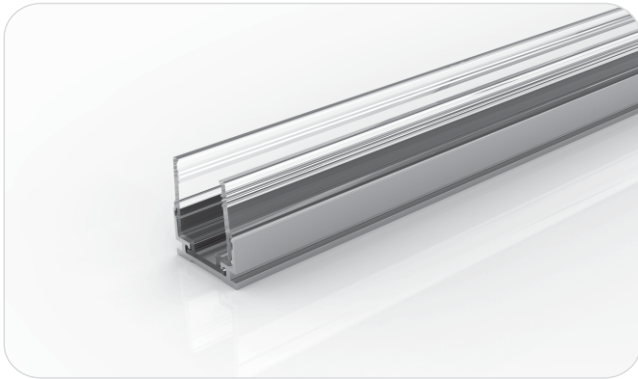

Note: Unless otherwise stated, the tolerance of the profile is ±0.5mm.

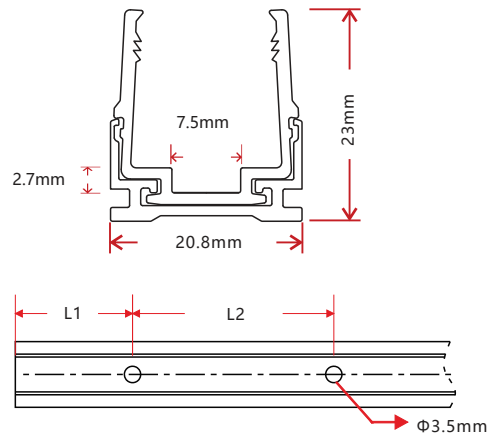

Installation Way



Model	W*H(mm)	Standard Length (mm)	L1 (mm)	L2 (mm)	Screw Hole (mm)	Hole Number	For Product
F22-PA/PL	20.8*23	35	17.5	/	Ø3.5	1	F22
		500	50	200	Ø3.5	3	F22
		1000	100	200	Ø3.5	5	F22
		2000	100	200	Ø3.5	10	F22

4.4 Cable Exit Oriented Aluminum Profile (Applicable to Injection-moulded Connector Only)

4.4.1 Spring Clip Aluminum Profile, Bottom Feed

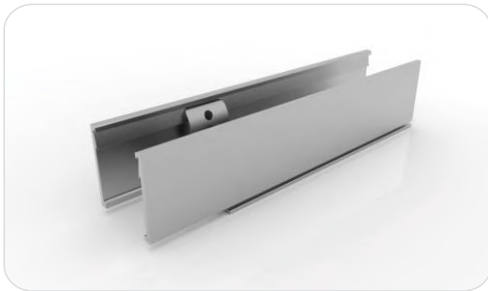

Model: F22-SCA/PL-B

Note: Unless otherwise stated, the tolerance of the profile is ±0.5mm.

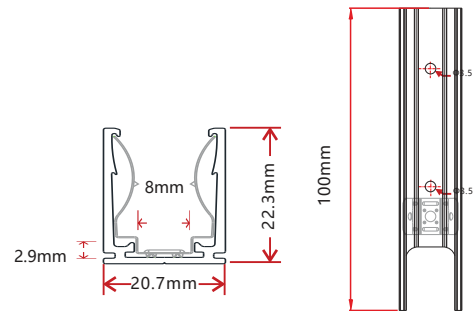

4.4.2 Spring Clip Aluminum Profile, Middle Feed



Model: F22-SCA/PL-M

Note: Unless otherwise stated, the tolerance of the profile is ±0.5mm.

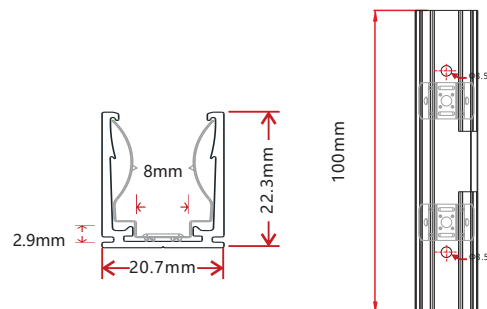

4.4.3 Spring Clip Aluminum Profile, Side Feed From Left

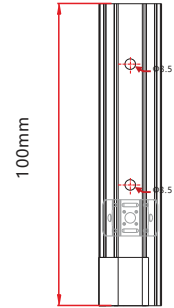
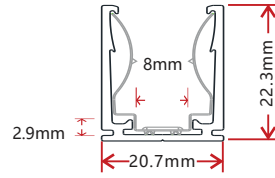
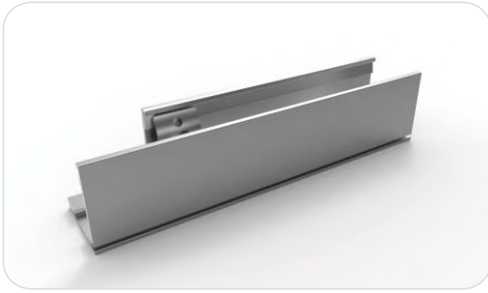

Model: F22-SCA/PL-SL

Note: Unless otherwise stated, the tolerance of the profile is $\pm 0.5\text{mm}$.

4.4.4 Spring Clip Aluminum Profile, Side Feed From Right

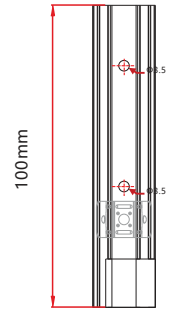
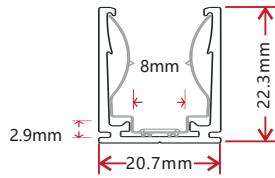

Model: F22-SCA/PL-SR

Note: Unless otherwise stated, the tolerance of the profile is $\pm 0.5\text{mm}$.

4.5 Corner Aluminum Profile (Applicable to Injection-moulded Connector Only)

4.5.1 L Shape Spring Clip Aluminum Profile

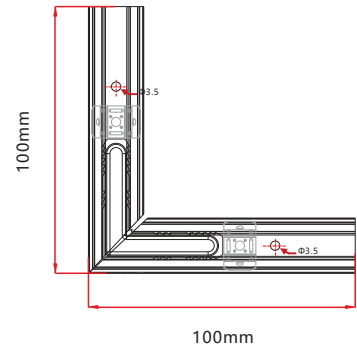
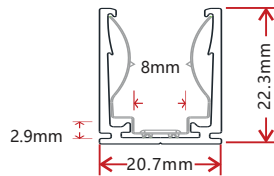
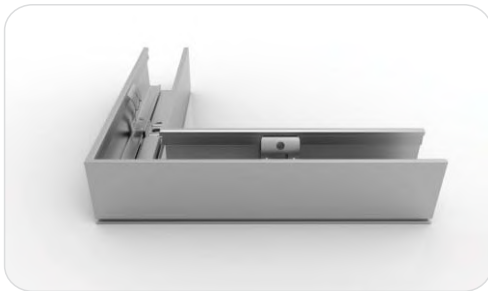

Model: F22-SCA/PL-L

Note: Unless otherwise stated, the tolerance of the profile is $\pm 0.5\text{mm}$.

4.5.2 Inward L Shape Spring Clip Aluminum Profile

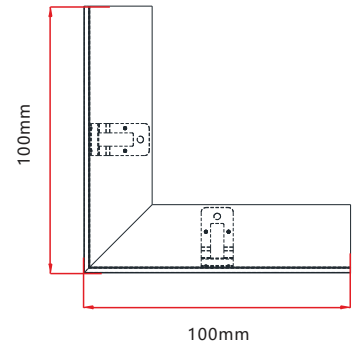
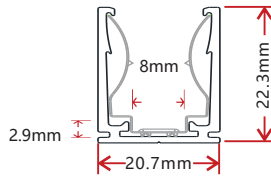

Model: F22-SCA/PL-IL

Note: Unless otherwise stated, the tolerance of the profile is $\pm 0.5\text{mm}$.

4.5.3 Outward L Shape Spring Clip Aluminum Profile

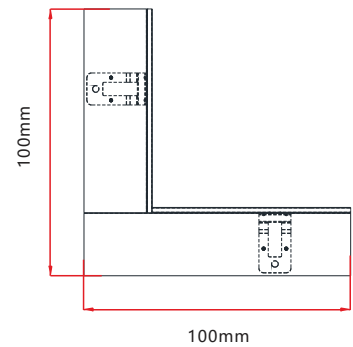
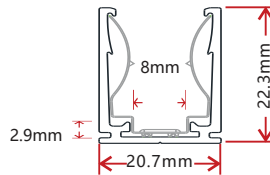
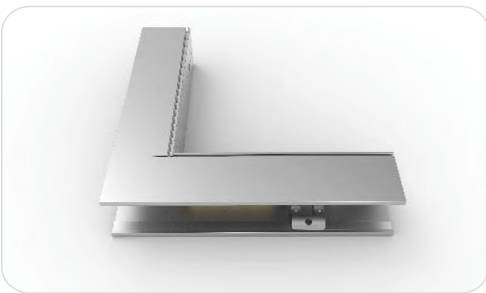

Model: F22-SCA/PL-OL

Note: Unless otherwise stated, the tolerance of the profile is $\pm 0.5\text{mm}$.

4.5.4 T Shape Spring Clip Aluminum Profile

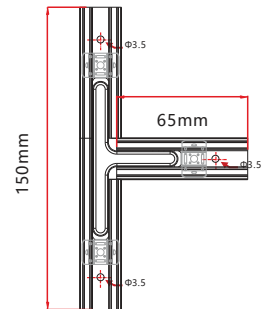
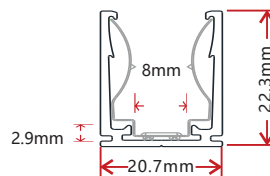

Model: F22-SCA/PL-T

Note: Unless otherwise stated, the tolerance of the profile is $\pm 0.5\text{mm}$.

4.5.5 X Shape Spring Clip Aluminum Profile

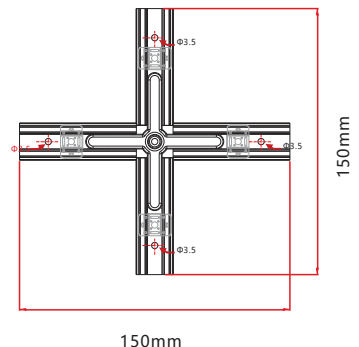
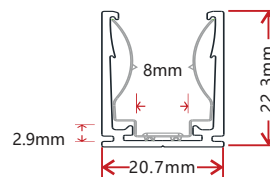

Model: F22-SCA/PL-X

Note: Unless otherwise stated, the tolerance of the profile is $\pm 0.5\text{mm}$.

4.6 Bendable Stainless Steel Profile



Model: F22-CS/PL

Note: Unless otherwise stated, the tolerance of the profile is ±0.5mm.

Installation Way

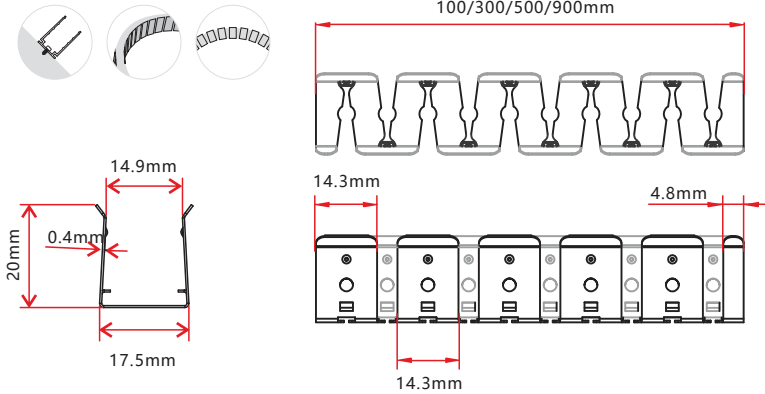

4.7 Recessed Mounting Profile

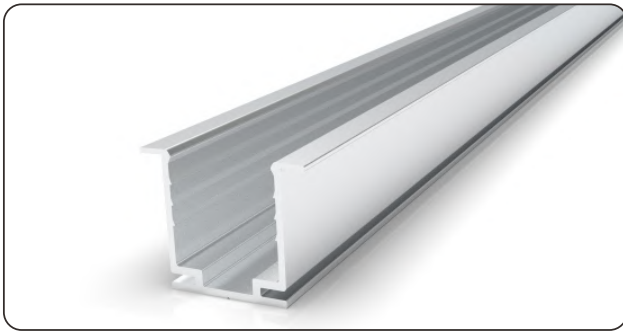

Note: Unless otherwise stated, the tolerance of the profile is ±0.5mm.

Installation Way

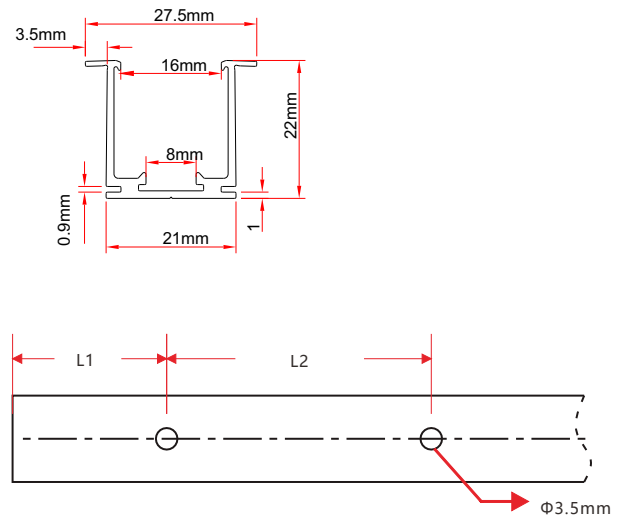

Model	W*H(mm)	Standard Length (mm)	L1 (mm)	L2 (mm)	Screw Hole (mm)	Hole Number	For Product
F22-RMA/PL	18*13.2	35	5	25	Φ3.5	2	F22
		500	50	200	Φ3.5	3	F22
		1000	100	200	Φ3.5	5	F22
		2000	100	200	Φ3.5	10	F22

6. Appendix

6.2 Certificate

Certificating Type	Testing Organization	Certificate Serial Number	Report Reference
UL 2108	UL	20160726-E360029	E360029-20130322
CE-EMC	SGS	SZEM1712012372LMV	SZEM171201237201

6.3 Third-Party Test Report

Testing Item	Testing Organization	Report Number
RoHS	SGS	CANEC1202163502 A01
IP68: Screw type	TUV SUD	68.140.12.136.02
IP68: Clasp type	SGS	GZES140200135301 GZES140200135401 GZES140200135501 GZES140200135701 GZES140200135801
IPX8: Molding type	SGS	SZES141200357301 SZES141200357401 SZES141200357501
IPX8: Snap type	SGS	GZES160600792031

6.4 Reliability Test of Light

TESTING ITEM	PERFORMANCE	STANDARD/REFERENCE VALUE/DESCRIPTION
PHOTOMETRIC TESTING	Spectrum Analysis	IES LM 79 (lumen, CCT, CRI, XY, SDCM, wave length)
	Photometric Distribution	IES LM 79 (lumen intensity distribution & Lux diagram)
	Lumen maintenance & Life time	IES LM84 & IES TM28
TEMPERATURE RISE TESTING	Normal Temperature Test	UL1598 & UL2388 & IEC60598-1 & IEC60598-2-21
	Abnormal Operation Test	UL1598 & UL2388 & IEC60598-1 & IEC60598-2-21
MECHANICS & PHYSICS TESTING	Bending Test	Manufacturer-defined, 500 cycles
	Swing Test	UL2388, >750 cycles
	Tensile Test	Manufacturer-defined, > the weight of light in maximum connection length with both ends feed
	Twist Test	Manufacturer-defined, >200 cycles
	Ball impact	UL1598 & UL2388 & IEC60598-1 & IEC60598-2-21
	IK07 IK08	IEC62262
WEATHERING TESTING	Swimming Pool Water Immersion Test	GB9667, PH6.8-7.6, free chlorine 0.3-0.6mg/L
	Sea Water Immersion Test	IEC60598-1, Salinity 4%
	Salt Spray Test	IEC68-2-11
	Outdoor Exposure	Manufacturer-defined
ENVIROMENT TESTING	Flame Resistant Test	UL94
	UV Exposure Test	ASTMG 154, ISO 4892-3, UVA@340nm
	IPX5 IPX6 IPX7 IPX8	IEC60529
ENDURANCE & THERMAL TEST LAB	Temperature Shock Test	Manufacturer-defined, -40°C-60°C (typical temperature range)
	Constant Temperature Test	Manufacturer-defined, 70°C (typical temperature)

6.9 Wavelength of Color Light

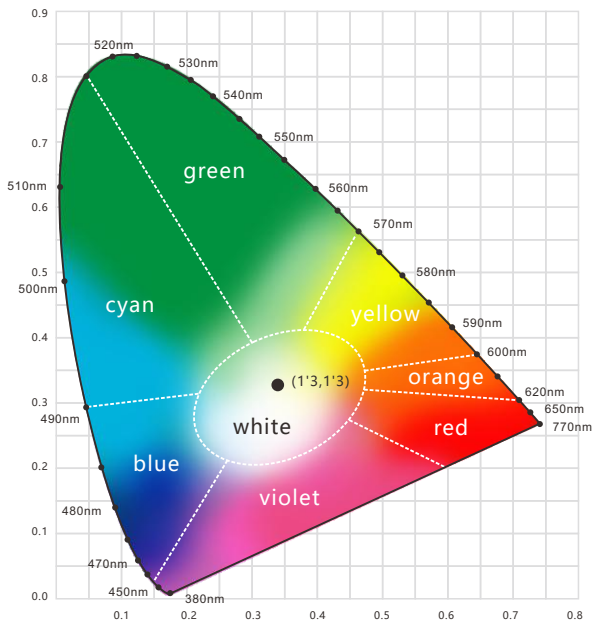

Light Color

